

## Capisaldi / Posts / Arranques

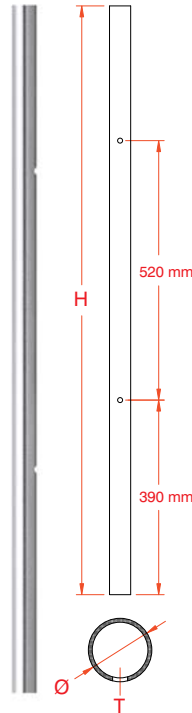

2 x M8

COD.	H	Ø	T
------	---	---	---

05.001C.04S	1180 mm	42,4 mm	2,6 mm
-------------	---------	---------	--------

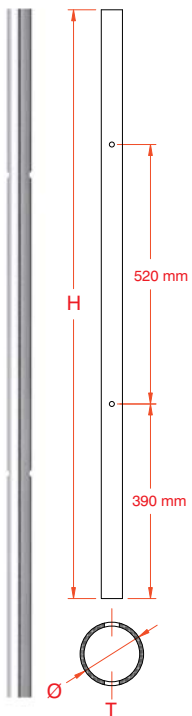

4 x M8 - 180°

COD.	H	Ø	T
------	---	---	---

05.010C.04S	1180 mm	42,4 mm	2,6 mm
-------------	---------	---------	--------

### NOVITA' - NEWS - NOTICIAS

**Possibilità di forare i capisaldi in tubo secondo le vostre esigenze / Customized posts / Posibilidad de pinchar los arranques en tubo según vuestras exigencias**

EZ Inox, dando così seguito alle molteplici richieste giunte dagli operatori del settore, è lieta di annunciare che ora è in grado di fornire anche i piantoni in tubo forati a misura, seguendo le specifiche che ci vorrete comunicare. / EZ Inox, following the suggestions of many business operators, is glad to present the new range of customized posts. / EZ INOX, después de las sugerencias de muchos operadores del negocio, está alegre de presentar la nueva gama de postes modificados para requisitos particulares.

Basterà rispettare i seguenti parametri / We can offer customized posts choosing from the following specifications / Podemos ofrecer los postes modificados para requisitos particulares que eligen de las especificaciones siguientes:

#### Tipo di tubo / Type of tube / Tipo de tubo:

tondo / round tube / tubo redondo 42,4 mm - spessore / thickness / grueso 2,00 e 2,60 mm;  
 tondo / round tube / tubo redondo 48,3 mm - spessore / thickness / grueso 2,00 e 2,60 mm;  
 quadro / square tube / tubo cuadrado 40x40 mm - spessore / thickness / grueso 2,00 mm.

Lunghezza piantone / Length: fino a / up to / largo máximo: 1.500 mm.

#### Tipo di fori / Hole dimensions / Dimensiones del agujero:

tondo / round / redondo 10,20 mm. (per barra in tondo / for rod / por barra en redondo 10mm);  
 tondo / round / redondo 12,20 mm. (per barra in tondo / for rod / por barra en redondo 12mm);  
 tondo / round / redondo 14,20 mm. (per barra in tondo / for rod / por barra en redondo 14mm);  
 foro filettato / threaded hole / agujero roscado M6;  
 foro filettato / threaded hole / agujero roscado M8.

#### Posizione dei fori / Holes'position / Position des trous:

in linea / straight / En ligne;  
 180° o passanti / 180 degrees angle / ángulo de los grados 180°;  
 90° per angoli retti / 90 degrees angle / ángulo de los grados 90°.

Gli interessi tra i fori, così come tutte le misure intermedie, seguiranno le vostre indicazioni / The wheelbase of the holes, like all the internal dimensions, will follow your specifications. / La distancia entre ejes de los agujeros, como todas las dimensiones internas, seguirá sus especificaciones.

## Capisaldi / Posts / Arranques

**4 x M8 - 90°**

COD.	H	Ø	T
<b>05.020C.04S</b>	1180 mm	42,4 mm	2,6 mm

**4 x M8 - 135°**

COD.	H	Ø	T
<b>05.030C.04S</b>	1180 mm	42,4 mm	2,6 mm

**5 x M6**

COD.	H	Ø	T
<b>05.040C.04S</b>	1180 mm	42,4 mm	2,6 mm

**6 x M6**

COD.	H	Ø	T
<b>05.060C.04S</b>	1180 mm	42,4 mm	2,6 mm

**05.041C.04S** 1180 mm 42,4 mm 2,6 mm  
**5 + 5 M6 - 90°**

**05.061C.04S** 1180 mm 42,4 mm 2,6 mm  
**6 + 6 M6 - 90°**

**05.042C.04S** 1180 mm 42,4 mm 2,6 mm  
**5 + 5 M6 - 180°**

**05.062C.04S** 1180 mm 42,4 mm 2,6 mm  
**6 + 6 M6 - 180°**

## Capisaldi / Posts / Arranques



Esempio / Example / Ejemplo

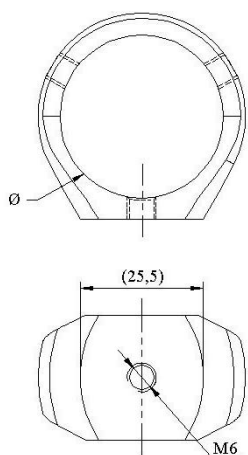

COD.

Ø

05.100A.04S  
05.100B.04S  
05.100D.04S

33,7 mm  
42,4 mm  
48,3 mm

Anello per caposaldo / Ring for post  
Anillo por arranques

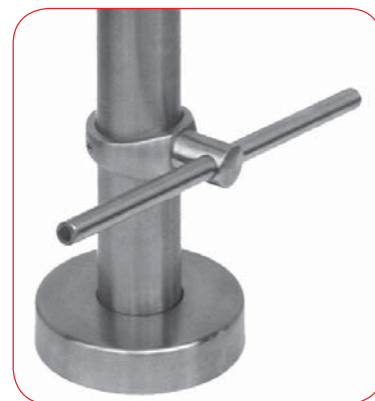
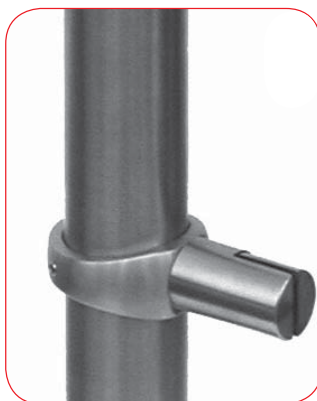

Esempio / Example / Ejemplo

**Capisaldi / Posts / Arranques**  
(Completi di componenti / Accessories included / Accesorios incluidos)

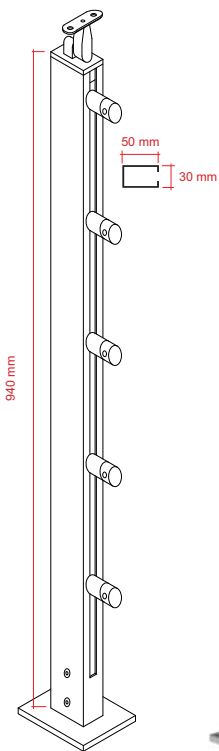
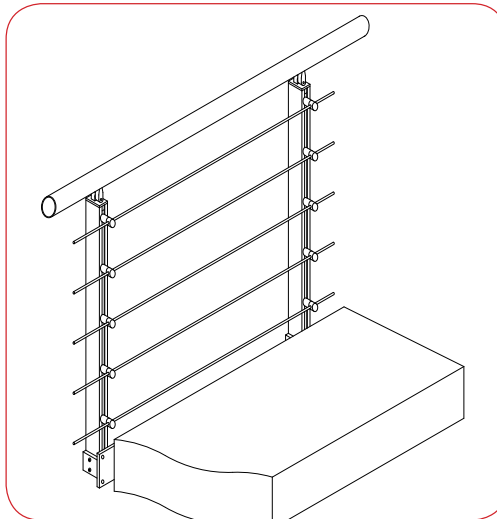

**Caposaldo rettangolo a pavimento con supporti barra 12mm**

**Rectangular post on floor with 12mm bars holders**

**Arranques rectángulo a suelo con soportes barra 12 mm**

**COD. H**

**05.200X.04S 940 mm**

**Caposaldo rettangolo a parete con supporti barra 12mm**

**Rectangular post for wall with 12mm bars holders**

**Arranques rectángulo a pared con soportes barra 12 mm**

**COD. H**

**05.210X.04S 1065 mm**

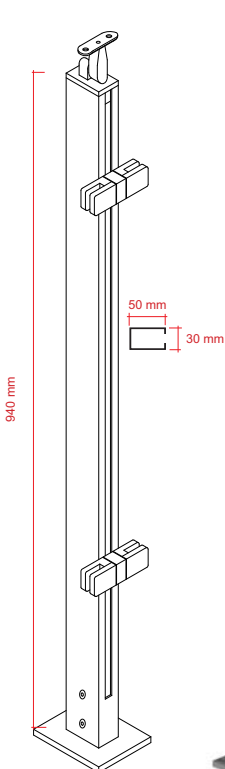
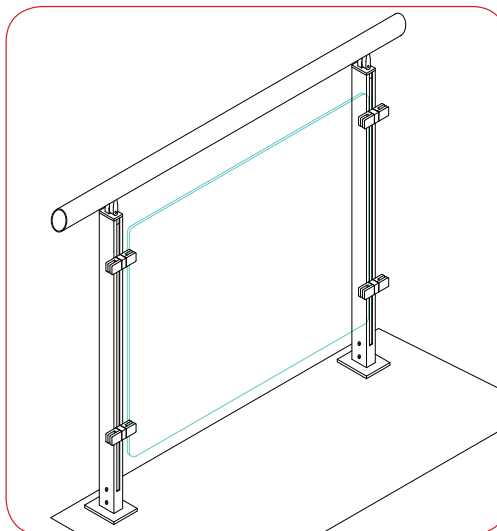
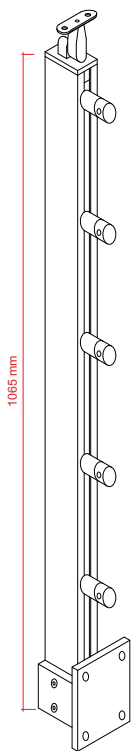

**Caposaldo rettangolo a pavimento con pinze per vetro**

**Rectangular post on floor with glass clamps**

**Arranques rectángulo a suelo con pinzas por vidrio**

**COD. H**

**05.220X.04S 940 mm**

**Caposaldo rettangolo a parete con pinze per vetro**

**Rectangular post for wall with glass clamps**

**Arranques rectángulo a pared con pinzas por vidrio**

**COD. H**

**05.230X.04S 1065 mm**

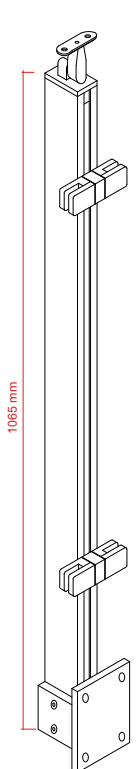
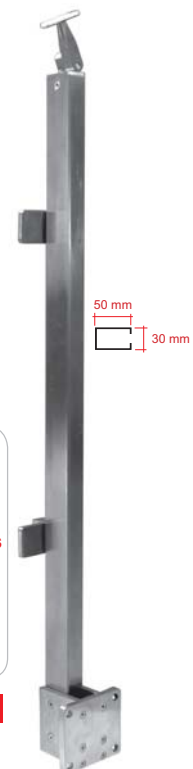

## Capisaldi / Posts / Arranques

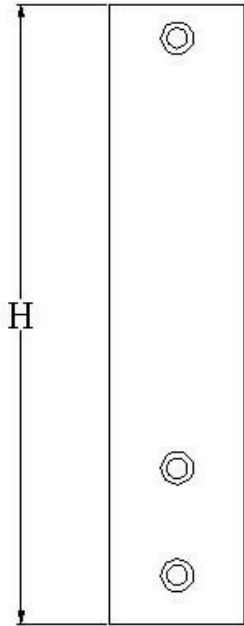
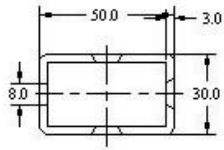

**COD.** **H**

**05.300X.04S** 940 mm  
**05.301X.04S** 1065 mm

Corpo centrale caposaldo rettangolare  
 Central body for rectangular post  
 Cuerpo central des arranques rectangulares

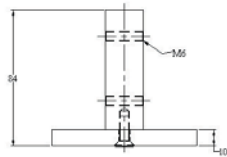
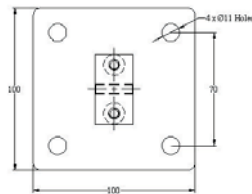
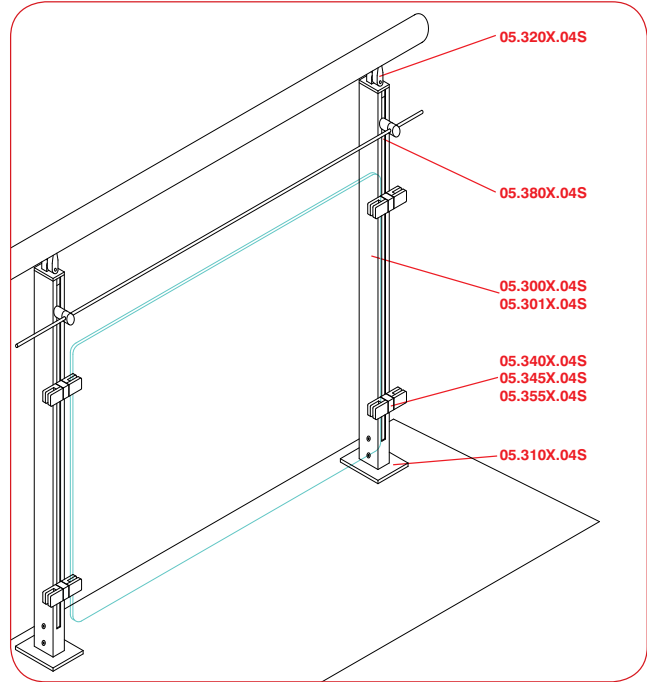

**COD.**

**05.310X.04S**

Supporto a pavimento / Floor bracket / Soporte a suelo

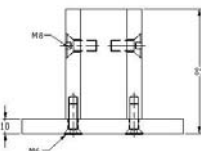
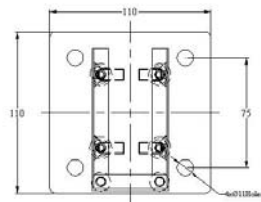

**COD.**

**05.311X.04S**

Supporto a parete / Wall bracket / Soporte a pared

## Capisaldi / Posts / Arranques

COD.

05.320X.04S

Supporto corrimano / Handrail support  
Soporte por pasamano

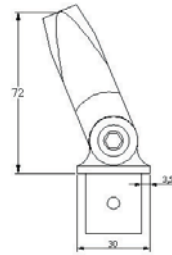
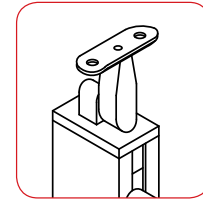
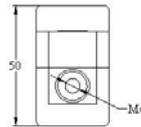

COD.

05.330X.04S

Calotta di copertura / End cap / Casquete de cobertura

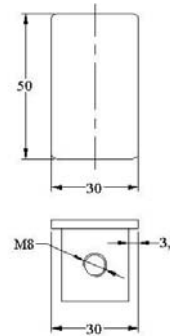

COD.

05.340X.04S

05.345X.04S

05.355X.04S

05.340x.04S Supporto per pinza / Glass support / Soporte por pinza - dim.50x40mm  
05.345x.04S Supporto per pinza / Glass support / Soporte por pinza - dim.63x45mm  
05.345x.04S Supporto per pinza / Glass support / Soporte por pinza - dim.45x45mm  
05.355x.04S Supporto per pinza / Glass support / Soporte por pinza - dim.55x55mm

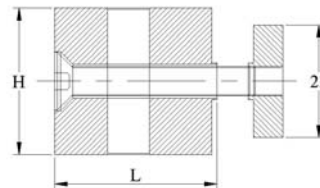

COD.

05.440X.04S

05.445X.04S

05.455X.04S

05.440x.04S Placca di chiusura per pinza / Closing plate for clamp  
Chapa de cierre por pinza - dim.50x40mm  
05.445x.04S Placca di chiusura per pinza / Closing plate for clamp  
Chapa de cierre por pinza - dim.63x45mm - dim.45x45mm  
05.455x.04S Placca di chiusura per pinza / Closing plate for clamp  
Chapa de cierre por pinza - dim.55x55mm

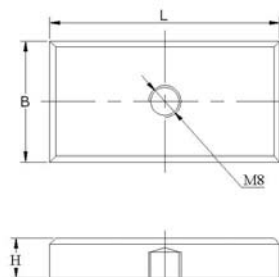

COD.

05.380X.04S

Supporto scorrevole / Slider / Soporte corredizo

